



5599 Highway 31 West  
Portland, TN 37148  
(615)325-2774

# PS-1220-15

Pg.1 . TITLE PAGE    Pg.3 . PS-1220-15 BOM

Pg.2 . PS-1220-15

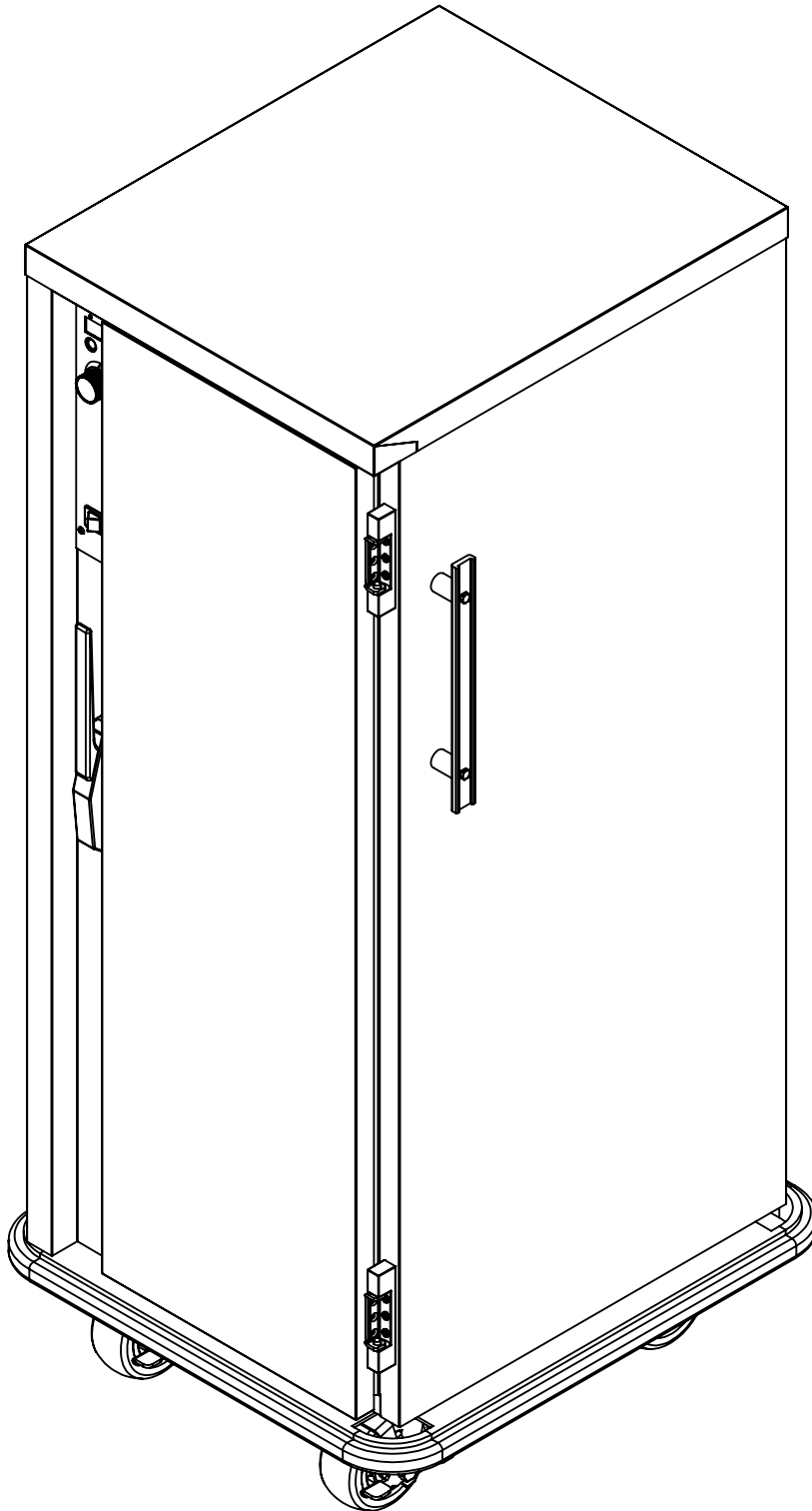

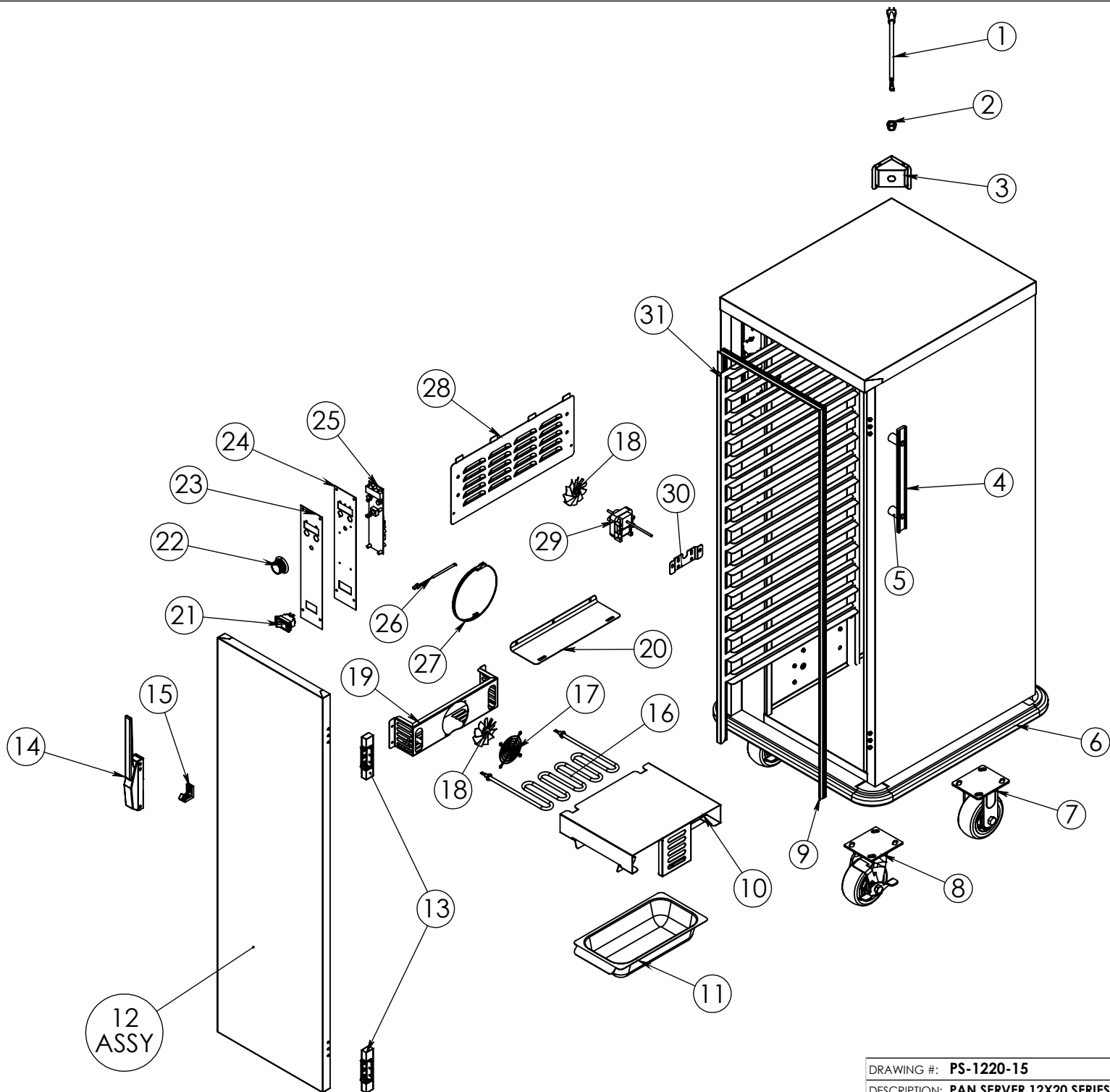

DRAWING #: <b>PS-1220-15</b>	
DESCRIPTION: <b>PAN SERVER 12X20 SERIES</b>	
DRAWN BY: DP	LAST SAVED BY: andrew82

ITEM NO.	QTY.	PART NO.	DESCRIPTION
1	1	CRDSET10-115	CORD 12' 115V 5-15P 14GA 3WR 15AMP
2	1	BSH STRN 3	STRAIN RELIEF FOR 15 AMP CORD
3	1	69729	HUMI TRI-CORD BRCKET DD .672X .750
4	2	HDL-125-AL	HANDLE PUSH ALUMINUM 12.5" LONG
5	4	SPCR125X.330	HANDLE SPACERS FOR HDL 21 AND 12.
6	1	Z-200-1058	PS-1220-15 BUMPER ASSEMBLY
7	2	CSTR 52-R-PPF	CASTER 5" RIGID EZ ROLL POLY
8	2	CSTR 52-SB-PPF	CASTER 5" SWIVEL BRAKE EZ ROLL POLY
9	1	GSKT-D-48-094X14-600	SILICONE DOOR GASKET D 48.094X14.60
10	1	67068	HUMITEMP TUNNEL 10.25
11	1	WATER-PAN-3RD-WHDL	WATER PAN 2.5" X6.75 X
12	1	Z-301-3932 ( INCLUDE 13 , 14 , & 15 )	PS-1220-15 DOOR ASSY EDG/EDG RH
13	2	HNG-214	DOOR HINGE EDGEMOUNT .875"
14	1	LTH-DR	DOOR LATCH EDGEMOUNT STYLE CHROME
15	1	STK LTH 1	DOOR LATCH STRIKE FOR LTH DR
16	1	EL1250-120-HT	ELEMENT 1250 WATT 120 VOLT 8" HT
17	1	GRD FAN	FAN GUARD
18	2	BLD FAN AL	FAN BLADE 3" ALUMINUM
19	1	4011	HUMITEMP BLOWER HOUSING
20	1	4041	HUMITEMP BLOWER LID
21	1	SWH RCK E1	SWITCH NON-LT ROCKER 125/250V 20AMP
22	1	KNB H6	KNOB WITH ARROW
23	1	CNTRL PNL T-STAT V-G	OVERLAY, HUMI-TEMP IEC VERTICAL
24	1	81388	ELECTRONIC T-STAT RCK E1 SWITCH
25	1	T-STAT ELE 2	ELEC THERMO HEAT CNTRL VERTICAL IEC
26	1	PRB RTD T	RTD TEMPERATURE PROBE FOR T-STAT
27	1	PRB HARNESS 36	36" PROBE HARNESS - T-STAT ELE
28	1	53454	HUMITEMP LOUVER PANEL W/TABS
29	1	MTR BY 120 92	MOTOR DUAL SHAFTED 120 VOLT
30	1	80610	BRACKET MOTOR MNT FOR BAY MTR
31	2	57236	PS-1220-15 RACK 2.625"



DRAWING #: **PS-1220-15**  
DESCRIPTION: **PAN SERVER 12X20 SERIES**

DRAWN BY: DP LAST SAVED BY: dplodzien