

CLYMATE IQ CABINETS & DRAWERS



OPERATING INSTRUCTIONS

FOR EQUIPMENT:

*PHTT Series
PHTT-CV Series
PHTT-1220 Series
PHTT-1826 Series
PHTT-DR Series
PHTT-CC Series
PHTT-2333 Series*

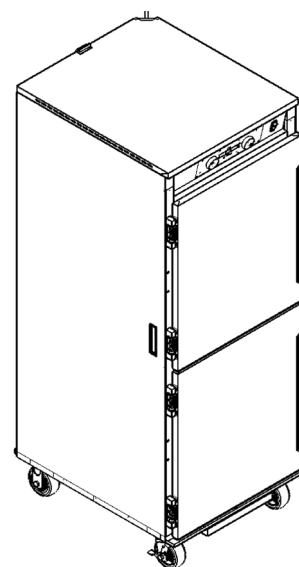
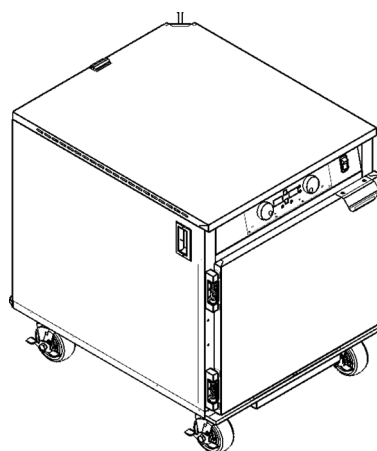
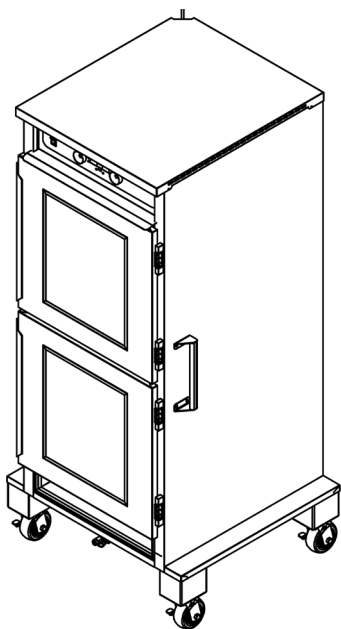

Warning: Do not operate this equipment unless you have read and understood the contents of this manual! Failure to follow the instructions contained in this manual may result in serious injury or death. This manual contains important safety information concerning the maintenance, use, and operation of this product. If you're unable to understand the contents of this manual, please bring it to the attention of your supervisor. Keep this manual in a safe location for future reference.

CLYMATE IQ® CABINETS & DRAWERS

TABLE OF CONTENTS

- 1. Table of Contents ----- 2
- 2. Introduction ----- 2
- 3. Important Safety Information ----- 2
- 4. Model Description ----- 3
- 5. Delivery Inspection ----- 4
- 6. Unpacking ----- 4
- 7. Electrical Requirements ----- 5
- 8. Installation ----- 5
- 9. Transporting the Unit ----- 5
- 10. Controls ----- 6
- 11. Operation ----- 8
- 12. Performance ----- 8
- 13. Best Practices ----- 9
- 14. Cleaning and Maintenance ----- 9
- 15. Service Information ----- 10
- 16. Warranty ----- 10
- 17. Warranty Information ----- 10
- 18. Important Owner Information ----- 11

INTRODUCTION

Welcome to the operation manual for FWE's Clymate IQ® Heating System. The Clymate IQ® series provides advanced climate control with precise regulation of both temperature and humidity, designed to maintain the quality, texture, and flavor of your food products. This high-performance heating system delivers unparalleled accuracy, making it ideal for food service environments where consistent results and peak efficiency are crucial.

The Clymate IQ® system allows independent control over temperature (ranging from 90°F to 200°F) and relative humidity (from 0% to 90%), enabling you to create the optimal holding environment for a wide variety of foods. Whether you need to retain moisture or provide a crisp texture, the intuitive control panel makes it easy to adjust settings, providing professional results every time. The system's fast recovery ensures that temperature and humidity return to set levels quickly, even during frequent door openings.

Constructed with a rugged, stainless-steel body, Clymate IQ® units are built to endure the rigors of a busy kitchen while remaining easy to clean. The removable water pan and adjustable stainless steel tray slides enhance flexibility and sanitation, streamlining your workflow during peak service times. Additionally, the unit's tri-directional cord placement allows for flexible installation options, making it easier to integrate into any kitchen layout.

This manual is designed to provide essential safety, installation, and operating instructions for units equipped with the Clymate IQ® system. **FWE strongly recommends that you read and follow all safety, installation, and operation guidelines before installing and using the unit to ensure optimal performance and longevity.**

IMPORTANT SAFETY INFORMATION

Read the following important safety information before using this equipment to avoid serious injury or death and to avoid damage to equipment or property.



Warning: Warning indicates a hazardous situation which, if not avoided, could result in death or serious injury.



Caution: Caution indicates a hazardous situation which, if not avoided, could result in minor or moderate injury.



Notice: Notice is used to address practices not related to personal injury.

1. Electrical Shock Hazard **WARNING** 
 - A. Plug Unit into a properly grounded electrical outlet of the correct voltage, size, and plug configuration.
 - B. Turn OFF power switch, unplug power cord, and allow unit to cool before performing any cleaning, adjustments, or maintenance.
 - C. Do NOT submerge or saturate with water. Unit is not waterproof. Do not operate unit if unit has been submerged or saturated with water.
 - D. Unit is not weatherproof. ONLY use unit indoors where ambient air temperature is at least 70°F or 21°C.
 - E. This unit is not "jet-proof" construction. Do not use jet-clean spray to clean this unit.
 - F. Do not steam clean or use excessive water on unit.
 - G. Turn power switch OFF and allow unit to cool before draining, filling, or moving water pan.
 - H. Do not pull unit by the power cord.
 - I. Discontinue use and unplug unit if power cord is frayed or worn.
 - J. Do not attempt to repair or replace a damaged power cord. Cord must be replaced by FWE, an authorized FWE Service Agent, or a person with similar qualifications.
 - K. This unit must be serviced by qualified personnel only. Service by unqualified personnel may lead to electrical shock or burn.
 - L. Service by unqualified personnel may negate unit warranty.
 - M. Use only genuine FWE Replacement Parts when servicing this unit. Failure to use Genuine FWE Replacement Parts will void all warranties and may subject operators of the equipment to hazardous electrical voltage, resulting in electrical shock or burn. Genuine FWE Replacement Parts are specified to operate safely in the environments in which they are used. Some aftermarket or generic replacement parts do not have the characteristics that will allow them to operate safely in FWE equipment.



CLYMATE IQ® CABINETS & DRAWERS

2. General Use **WARNING**

- A. Locate unit a minimum of 1" (25mm) from combustible walls and materials. If safe distances are not maintained, combustion or discoloration could occur.
- B. Make sure food product has been heated to the proper food-safe temperature before placing in unit. Failure to heat food properly may result in serious health risks. This unit is for holding pre-heated food product only.
- C. FWE is not responsible for actual food product serving temperature. It is the responsibility of the user to ensure that food product is held and served at a safe temperature.
- D. Make sure all operators have been instructed on the safe and proper use of the unit.
- E. The unit is not intended for use by children or persons with reduced physical, sensory, or mental capabilities. Ensure proper supervision of children and keep them away from the unit.
- F. This unit has no "user-serviceable parts", If service is required on this unit, contact an Authorized FWE Service Agent, or contact the FWE Service Department at 1-800-222-4393

3. Burn Hazard **CAUTION**

- A. Some exterior surfaces on the unit will get hot. Use caution when touching the exterior of unit.
- B. Turn off unit and allow it to cool before draining water from water pan.
- C. Locate unit in an area that is convenient for use. The location should be level to prevent unit or contents from falling accidentally and strong enough to support the weight of the unit and contents.
- D. Do not overfill water pan. Overfilling can cause water to leak onto floor and create a slipping hazard.
- E. Transport unit in upright position only. Make sure all water is drained prior to transport.

4. Important Notice **NOTICE**

- A. Do not lay unit on side with control panel or damage to unit could occur. Make sure all water is drained prior to laying unit on its side.
- B. Use non-abrasive cleaners and cloths only. Abrasive cleaners and cloths could scratch finish of unit, marring its appearance and making it susceptible to soil accumulation.
- C. Use of distilled water in water reservoir of humidified units is recommended. If non-distilled water is used, reservoir will require periodic cleaning and deliming (refer to maintenance section for cleaning procedure). Damage to unit caused by liming or sediment buildup is not covered under warranty.
- D. Clean unit daily to avoid malfunctions and maintain sanitary operation.
- E. Do not locate unit in area with excessive air movement around unit. Avoid areas that may be subject to active air movements or currents (i.e. near exhaust fans/hoods, air conditioning ducts, and exterior doors).

MODEL DESCRIPTION

Clymate IQ® Series Heat System

The Clymate IQ® Heating System offers precise control of both temperature (90°F to 200°F) and humidity (0% to 90%), ensuring the perfect environment for holding a wide range of foods, from moisture-rich dishes to items that need to stay crisp. Its advanced push/pull air circulation system distributes heat and moisture evenly throughout the cabinet, maintaining food's ideal texture, moisture, and flavor on every shelf. The system can adapt to different menu items, allowing you to switch between settings effortlessly to meet the specific requirements of each dish.



Water evaporates to condition the cabinet



Sensors communicate temperature and humidity percentage

Heating element within water causes humidity to match set humidity percentage

With fast recovery after door openings, the Clymate IQ® quickly restores set conditions, ensuring consistent food quality even during high-demand service times. Whether retaining crispness or preserving moisture, the Clymate IQ® heat system delivers reliable, professional performance with every use, making it an essential tool for any kitchen.

Clymate IQ® Model Series Specifications

Using a mobile device, scan the QR code above your product series to view that series specification sheet in PDF format.

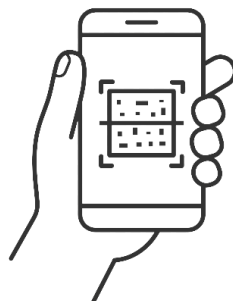

CLYMATE IQ® CABINETS & DRAWERS

Units Covered in this Manual

This manual provides operational guidance for both the standard Clymate IQ® PHTT units and the PHTT-DR drawer units, along with other models that incorporate the Clymate IQ® climate control system. While these units may serve different functions or vary in appearance, all utilize one of the two control panel designs covered in this manual. Whether your unit is configured with drawers, doors, or unique holding capacities, the control panel functions consistently across models, ensuring ease of use and dependable performance.

DELIVERY INSPECTION

1. FWE cannot assume responsibility for loss or damage suffered in transit. The carrier assumes full responsibility of delivery in good order when shipment was accepted.
2. All units are factory tested for performance then carefully packaged and certified free from defects when shipped.
3. Inspect the packaging for external damage when received. If damage is found, follow FWE's policy on damaged goods as outlined below.

FWE's Policy on Damaged Goods:

1. **VISIBLE DAMAGE** (Packaging has visible damage when received):
 - A. Receiver should not accept delivery of the unit.
 - B. Receiver should sign the bill of lading and clearly indicate which merchandise is being "refused due to damage".
2. **CONCEALED DAMAGE** (Unit has damage that could not be detected until the packaging was removed):
 - A. Receiving should inspect the unit for concealed damage inside and out as soon after delivery as possible.
 - B. If damage is discovered:
 - I. Save all packaging materials for inspection.
 - II. Immediately inform your dealer and trucking company within 5 days of delivery or claim may be denied. Receiver must call the carrier to schedule an inspection of the damaged unit within 15 days.
 - III. Contact FWE customer service at 1-800-222-4393 to alert them of the situation.
 - IV. Under no circumstances may damaged unit be returned to FWE without a prior written factory Return Merchandise Authorization (RMA).
 - V. **CONCEALED DAMAGE MUST BE RETURNED WITHIN 5 BUSINESS DAYS OF DELIVERY OR CLAIM WILL BE DENIED.**

UNPACKING

1. Initial Inspection and Preparation:

Your Clymate IQ® Holding Cabinet is meticulously packaged and dispatched from our manufacturing facility securely mounted on a wooden pallet and encased within a robust cardboard carton. The carton's integrity is reinforced with heavy-duty staples and affixed to the pallet with industrial-grade poly strapping. Prior to carton removal, ensure all staples are removed to prevent any scratches to the cabinet's surface.

2. Carton and Packing Material Removal:

After removal of the strapping material and cardboard carton, proceed to delicately remove all interior cardboard padding. This includes the removal of any tray spacers and protective foam blocks positioned atop any vertical supports that were placed to safeguard the unit during transport.



NOTICE: If laying the unit on its side, ensure all water is fully drained. Avoid positioning the unit on the side with the control panel to prevent potential damage. When placed on its side, use a piece of cardboard between the cabinet and the floor to protect the cabinet's finish from any abrasions.

3. Unit Mobilization:

In instances where your unit is equipped with casters, gently tilt the cabinet to remove caster blocks protecting the casters during transport. It is imperative to employ a two-person team lift strategy to mitigate any risk of personal injury or damage to the unit.

4. Positioning the Unit:

Once all packing materials have been removed, carefully maneuver the unit off the pallet, guiding it to its designated operational location. Please follow *installation* instruction on **page 5** for a complete guide on optimal placement of your unit.

5. Documentation Management:

After setting up your unit, if there are any accompanying documents ensure they are saved for later use and guidance. The digital versions of these materials are accessible via a QR scan on the side of the unit. See **Page 5** under "QR Code for Quick Access" for easy retrieval.

6. Slide Adjustment (If Applicable):

Should your unit feature adjustable slides, reposition these slides to your preferred locations per your specific holding requirements.



NOTE: ALWAYS ensure safety precautions are adhered to during the unpacking and installation process to prevent potential injury or damage to the equipment.

CLYMATE IQ® CABINETS & DRAWERS

ELECTRICAL REQUIREMENTS

For the optimal and safe operation of your Clymate IQ® Heating and Holding Cabinet, it's essential to connect it according to its specific electrical requirements. These vary based on the series, model, unit numbers, and build specifications of your product.

1. Finding Your Electrical Specifications on Serial Tag:

The specific voltage and amps are found on your unit's serial tag. Serial tags are located on the top rear / back panel of the outside of your unit on the same side as your power cord.

2. Finding Your Electrical Specifications Online:

We've made it easy for you to access this information through our dedicated webpage. Simply scan this QR Code, input your serial number to retrieve the precise electrical specifications for your unit.



3. QR Code for Quick Access:

In addition to our online resources, each FWE-manufactured unit comes with a QR code attached to its serial tag. Scanning this code with your mobile device will instantly direct you to the webpage, allowing for convenient and quick access to all the necessary electrical details.



Scan the QR code to the right to view video on how to locate serial tag QR code for information, manuals, parts, and more!

INSTALLATION

1. Location:

Place the unit in an area with a stable ambient air temperature of at least 70°F (21°C). Prioritize locations free from fluctuating air currents, especially those caused by exhaust fans, ventilation ducts, and air conditioning. Avoid areas subject to drafts, such as near frequently opened doors, and ensure the unit isn't situated directly beneath ventilation hoods. These disturbances can interfere with the unit's airflow, leading to suboptimal performance when the door is open.

2. Stability:

Ensure the unit is stationed on solid, level flooring.

3. Electrical Safety:

Connect the unit to a grounded electrical receptacle matching the unit's voltage, size, and plug configuration. Refer to the

Electrical Requirements section on *page 4 & 5* for where to find your unit's detailed electrical requirements.

4. Clearance and Door Access:

Maintain a minimum clearance of 6 inches between the unit's back and any wall or obstruction. This is vital to facilitate optimal airflow around the unit/ Furthermore, position the unit so its doors can open at least 90 degrees, facilitating easy access. The doors are designed to swing and latch to the side of the cabinet.

5. Water and Safety:

Install the unit away from areas prone to pooling water, ensuring its continued performance and safety.

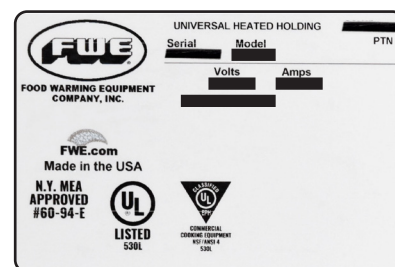

TRANSPORTING THE UNIT

1. Preparation:

Before attempting to relocate the unit, it's crucial to ensure the unit is fully powered off. Disconnect the power cord, ensuring it's neatly out of the way or securely wrapped around the rear handle to prevent tripping hazards.

2. Securing Doors:

Confirm that the unit's door is firmly closed, secured, and that all caster locks are disengaged. This step is essential to prevent any unintentional opening or movement during transport.

3. Handling:

When maneuvering the unit, firmly hold the dedicated handles located on the sides or rear. This will provide better control and stability during movement.

4. Usage:

This unit is specifically engineered for indoor use. It's not designed for outdoor or rugged terrain transport. Employ caution and only move the unit within interior spaces to avoid potential damage.



WARNING: Exercise heightened caution during transportation. The unit's heavy center of gravity is situated at the base. Loading the unit can shift this center, potentially making it top-heavy and reducing stability. Approach uneven surfaces, door thresholds, drains, and grates with heightened caution to prevent tipping or damage.

CLYMATE IQ® CABINETS & DRAWERS

CONTROLS

Electronic Control Panel

Temperature Control Dial

Turn this dial left or right to set the air temperature inside the cabinet.

The black arrow indicator points to the desired temperature set point.



Warning - Minimum & Safety Recommended Settings:

Air Temperature Setting:
160°F / 71°C

Actual Temperature Indicator

This amber light indicates that the unit is heating and will turn off when the unit reaches the set temperature

Thermometer

Measures and displays the air temperature (°F/°C) inside the cabinet.

“Display Values” Button

This button shows the current temperature and humidity levels inside the cabinet when pressed.

Humidity Percentage Display

This lcd panel shows the current humidity level inside the cabinet.

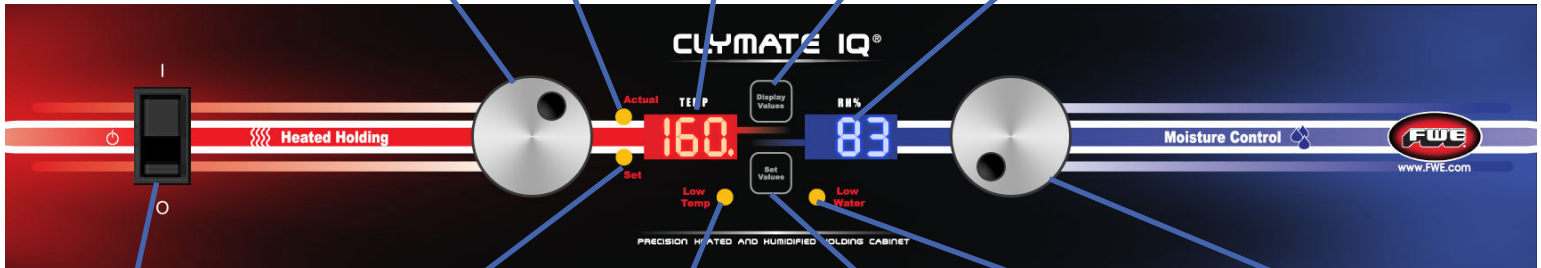

Power Switch

Turns the unit ON/OFF and activates the green “Power” light indicator located to the left.

Set Temperature Indicator

This amber light indicates that the temperature of the unit has reached the set temperature

Low Temperature Indicator

This amber light indicates that the unit is heating and will turn off when the unit reaches the set temperature

“Set Values” Button

This button shows the current temperature and humidity levels inside the cabinet when pressed.

Low Water Indicator

This light illuminates when the water level in the cabinet is too low.

Moisture Level Control Dial

Turn this dial left or right to set the moisture percentage inside the cabinet.

The black arrow indicator points to the desired temperature set point.

CLYMATE IQ® CABINETS & DRAWERS

Touch Screen Control Panel

Temperature Control and Temperature Display

Adjust the set temperature displayed between the arrows by pressing the up arrow to increase or the down arrow to decrease.
A red light will appear to the left of the Temperature Display to indicate that the unit is actively heating.

Warning - Minimum & Safety Recommended Settings:

Air Temperature Setting: 160°F / 71°C

PREHEAT Indicator

The word PREHEAT displays when the unit is preheating. Unit will beep when preheat is finished.

Moisture Level Control and Moisture Level Display

Adjust the set humidity level displayed between the arrows by pressing the up arrow to increase or the down arrow to decrease.

A blue light will appear to the right of the Moisture Level Display to indicate that the unit is increasing the moisture level within the cabinet

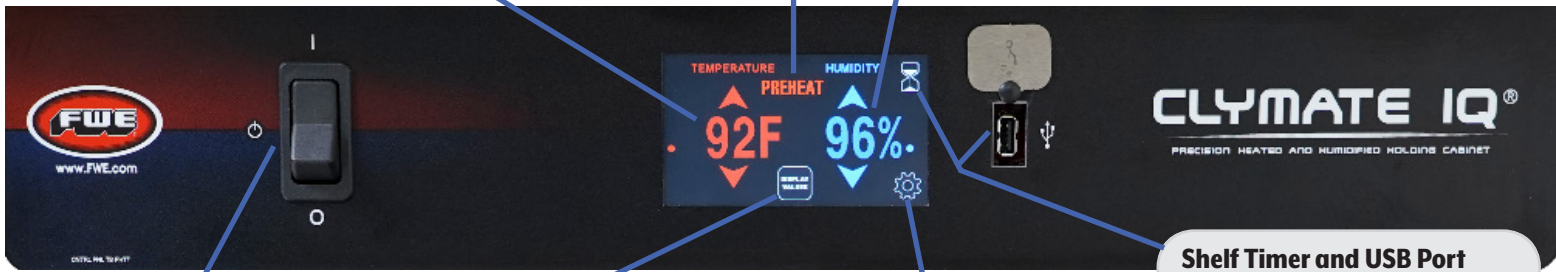

Power Switch

Turns the unit ON/OFF and activates the green "Power" light indicator located to the left.

Display Values Button

Pressing will display (in white) actual temperature and humidity values for 5 seconds.

Toolbox Icon

Pressing the toolbox icon will navigate you to the toolbox screen. (See below illustration)

Shelf Timer and USB Port

Please use your phone to scan the below QR Code for an introduction on how to use the shelf timers and USB Port

HACCP Icon

Pressing the HACCP Button navigates to the HACCP download screen.

Time/Date Icon Pressing the HACCP Button navigates to the HACCP download screen.

Temperature icon Pressing the °F or °C icon changes temperature units between the two.

Chef Lock Icon

Press and continue to hold* the lock icon until the keypad comes up. ENTER code 7654 and the arrow keys on the main screen will be disabled (locked) so the temperature cannot be changed. Repeat to unlock.

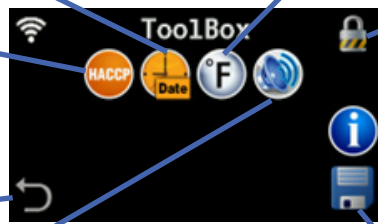

Back Icon

Press this button to navigate to the previous screen

Sound icon

Pressing this button changes sound to Off, Low or High.

Save Icon

This button must be pressed to save changes.

System Information Icon

Pressing this button will take you to the System Information Screen

CLYMATE IQ® CABINETS & DRAWERS

OPERATION

General:

Use the following procedures to operate FWE's Clymate IQ® Series.



WARNING: Read all safety messages in the **IMPORTANT SAFETY INFORMATION** section before operating this equipment.

Startup:

1. **Plug the unit** into a properly grounded electrical receptacle.
2. **Move the Power I/O switch** to the "on" position. This activates the display lights and the heating system.
3. **Toggle between °F and °C** by just pressing and holding the Display Values button AND the Temperature Control Dial for 10 seconds
4. **Preheat:** Actual/Set Point Display
 - A. If the cabinet is at room temperature when turned on or the user increases the *SET POINT*, the display will alternate between *ACTUAL* temp (*ACTUAL LED* illuminated) and *SET POINT* temperature every 5 seconds until the *SET POINT* is reached.
 - B. When the *SET POINT* is reached, 1 beep will sound and *SET POINT* will be displayed causing the alternating to stop.



NOTICE - Use of Distilled Water: It's recommended to use distilled water in the water reservoir to preserve the life of electrical and mechanical components. Using non-distilled water may lead to lime or mineral deposits, which are not covered under warranty.

Deionized water should not be used as it can shorten the life of the water reservoir and heating element.

NOTE: Unit failure caused by deionized water is not covered by warranty.



5. **Fill the Water Pan** with hot water.
 - A. The water pan is located on the bottom of the unit.
 - B. The amount of water required in pan is determined by the start-up time, length of holding, and level of humidity desired.
 - C. Fill to "Super-Charge Level" (lower mark) for immediate start-up. Fill to upper level mark for high humidity levels or long-term holding.



WARNING - ELECTRIC SHOCK HAZARD: Do not overfill water reservoir. Overfilling can cause electrical shock.

6. Setting Air Temperature:

Users are instructed to set the air temperature to their desired levels by turning the knobs on the control panel.

7. Allowing for Pre-Heating:

Users should allow the unit 30 minutes to reach the desired operating temperature before loading it with pre-heated food products. This ensures the proper functioning of the cabinet.



WARNING: Make sure food product has been heated to the proper food-safe temperature before placing in unit. Failure to heat food products properly may result in serious health risks. This unit is for holding pre-heated food products only.

BURN HAZARD: Some exterior surfaces on the unit will get hot. Use caution when touching these areas.

Setting the Air Temperature

1. Locate the temperature adjustment knob, or arrows on the control panel located to the left of the thermometer.
2. Press and hold the Set Values Button while simultaneously turning the Temperature Adjustment Knob to the desired temperature.
3. Wait until the amber Set Temperature Indicator light turns off to indicate unit has reached set temperature.
4. Load products.

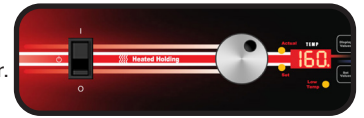

NOTE: Temperature settings may vary depending upon product make-up and consistency. The CABINET TEMPERATURE display shows the lowest temperature point inside the cabinet, not the product temperature.

Setting the Moisture Level

1. Locate the moisture adjustment dial, or arrows on the control panel located to the right of the Humidity Percentage Display.
2. Press and hold the Set Values Button while simultaneously turning the moisture adjustment dial to desired moisture level.
3. Check actual moisture level values within cabinet periodically by pressing the Display Values button to check and see if unit has reached set moisture level.
4. Load Products

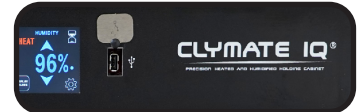
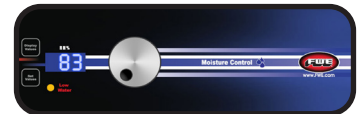

CLYMATE IQ® CABINETS & DRAWERS

The *Clymate IQ® Heating and Holding system* is designed to maintain the quality and safety of stored food by regulating temperature and passively adding humidity. This system gently circulates warm air over a water pan, creating a humid environment that keeps food moist and fresh for longer periods. This gentle heat system is particularly effective for environments where food needs to be held at safe temperatures without drying out, making it ideal for a wide range of food service operations and general holding applications.

1. Ambient Temperature:

Optimal performance is achieved in the standard kitchen environment of 70-75°F (21-24°C) and 40-50% relative humidity.

2. Placement:

Be mindful of your unit's placement. Locations with unusual temperatures and humidity levels can negatively impact the performance of the unit.

3. Ventilation:

Ensure proper airflow around the unit to maintain consistent heating, but avoid placement of units directly under HVAC ductwork.

4. Pre-heating:

Ensure the equipment is at the desired temperature before loading food to maintain quality. Only load hot food into hot cabinets, units are only designed to maintain temperature, not increase temperature or cook.

5. Loading Method:

Distribute items evenly to allow for optimal air circulation. Do not overload trays or block path of air circulation.

6. Door Management:

Minimize door openings to retain heat and ensure efficient operation.

7. Maintenance:

Regular checks and cleaning of the heating elements and door seals are crucial for performance.

2. DON'T:

- A. Never load COLD food into the cavity
- B. Never load food PRIOR to proper cavity pre-heat
- C. Never leave door open for long periods of time, especially when loading or unloading product
- D. Never crowd product or overload the unit, blocking proper air/heat distribution
- E. Never remove gasket or gasket support components
- F. Never use a holding cabinet as an oven

CLEANING AND MAINTENANCE



WARNING: Ensure the power switch is in the OFF position and unplug the power cord before beginning any cleaning, adjustments, or maintenance routines. Allow the unit ample time to cool down prior to these activities.

Positioning the unit indoors in an environment with a controlled air temperature, preferably above 70°F (21°C), as it is not constructed to be weather resistant.

The unit is not built to withstand "jet-proof" conditions. As such, abstain from using high-pressure jet sprays when cleaning the appliance.

It is advised to avoid steam cleaning or the application of excessive amounts of water to the unit.

Refrain from cleaning the unit while it is powered on (energized) or if the components are still hot.

Any serving required for this unit must be carried out by the certified and experienced professionals.

Daily Cleaning:

Daily cleaning of the unit is recommended to preserve the finish and to prevent scratches. At the end of the production day:

- A. Remove all products from the unit.
- B. Completely drain the water pan & wipe out any debris. *(If scale, typically white or off white in color, has build up on the water pan and/or element area, descale accordingly using either a vinegar & water solution or citric acid tablets according to tablet instructions)*
- C. Wipe down the interior of the unit. Ensure the interior is dry and clean of all debris.
- D. Leave the door slightly open during storage periods to prevent excess humidity from building up between production cycles.

Drawer Unit Cleaning

For PHTT-DR drawer units, clear debris from slides and rollers to keep drawers moving smoothly. Empty and wipe the removable water pan daily to prevent buildup. Regular care ensures proper performance and hygiene. See page 10 for detailed drawer slide cleaning instructions.

General Cleaning Guide of Stainless Steel:

Clean stainless steel with warm water, mild soap, & a soft cloth, wiping in the direction of the grain. Use stainless steel polish to restore shine and protect finish.



WARNING: Do NOT use stainless steel polish inside the unit!

BEST PRACTICES

Basic Do's and Don'ts of Hot Holding:

1. DO:

- A. Properly pre-heat cavity to desired temp, BEFORE loading food product
- B. ONLY load HOT food product into cavity, NEVER load cold food with the expectation of heating it
- C. Set cavity temperature 10-15°F OVER your desired product temperature
- D. Minimize door open time when loading/un-loading food product
- E. Ensure door fully closes every time it is accessed
- F. Allow space in between pans/product for air and heat to properly circulate.
- G. Keep door gaskets in place and clean of any debris
- H. Follow all maintenance and cleaning procedures daily for best performance

CLYMATE IQ® CABINETS & DRAWERS

For harder to clean stains, baking soda is recommended. Mix 1 TBSP to 1 pint of water. After cleaning unit with baking soda, remove any remaining baking soda residue by wiping the surface with a clean cloth soaked with warm water.

1. Before cleaning, switch the *POWER ON/OFF (I/O)* to the *OFF* position and disconnect the power cord from the power supply. Wait until the unit has sufficiently cooled down before proceeding.
2. Remove and wash all food pans.
3. Use a soft, damp cloth to cleanse both interior and exterior surfaces of the unit. For persistent stains, utilize a gentle cleaning agent, such as the baking soda and water compound mentioned above. Utilize a small brush with mild detergent for areas that are challenging to reach.
4. After cleaning, ensure to dry the unit with a soft, lint-free cloth to avoid scratches.
5. For the Lexan polycarbonate doors, a gentle washing with a solution of mild soap and water is recommended. Use a soft, damp cloth for wiping.



NOTICE: Avoid the use of abrasive materials such as paper towels or glass cleaning products.

6. The water pan should be emptied and sanitized as outlined in the “*Cleaning/Draining Water Pan*” instructions within the next section.

Cleaning/Draining Water Pan:

It is essential to drain the water pan daily as part of the routine cleaning process, prior to moving the cabinet, and during the “*Removing Lime and Mineral Deposits*” procedure.



WARNING - ELECTRIC SHOCK HAZARD: Turn OFF power switch, unplug power cord, and allow unit to cool before performing any cleaning, adjustments, or maintenance.

1. Ensure the unit is powered off by toggling the *POWER ON/OFF (I/O)* switch to the *OFF* position and disconnecting the power cord. Allow the unit to cool before beginning maintenance.
2. Remove heat tunnel by carefully sliding it out and then pulling up.
3. Carefully lift the water pan out from its position at the base of the unit.
4. Empty the water pan, and proceed to wash the pan thoroughly.
5. Once cleaned, reposition the water pan, followed by the heat tunnel, ensuring they are properly seated within the unit.

Removing Mineral Deposits:

Periodic maintenance is vital for the optimal performance of humidified units. The frequency of defilming will depend on the lime and mineral composition of the water in regular use.

Important Considerations:

It's advisable to carry out the maintenance at times when the unit is not needed imminently, such as at the end of the day.

De-Liming Procedure:

1. Power down the unit, disconnect from the electrical supply, and wait for the unit to cool.
2. Once cool, follow the steps outlined in the “*Draining the Water Pan*” section of this manual.
3. Prepare a de-liming solution by combining 75% water with 25% white vinegar, ensuring that only plain white vinegar is used.
4. Reconnect the unit's power supply and switch on the unit.
5. Adjust the air temperature control to the maximum settings and operate the unit for 30 minutes.
6. Afterwards, power down the unit, disconnect it from the power supply, and allow it to cool once more.
7. Drain the water reservoir using the “*Draining the Water Reservoir*” procedure again to remove the de-liming solution.
8. Rinse the water reservoir by filling and draining it with clean water several times until the outflow appears clear and free from any de-liming solution residue.
9. Once the reservoir is thoroughly rinsed, reconnect the unit to the power source and refill the reservoir following the daily operation guidelines proceeded in the *OPERATION* section of this manual.

Removing, Cleaning, and Reinstalling Sliding Drawers on PHTT-DR Units:

1. Power down the unit, disconnect from the electrical supply, and wait for the unit to cool.
2. Open the drawer and remove the pan from the drawer (if installed)
3. With the drawer fully extended, tilt drawer front up at at 45° angle.
4. Pull drawer forward. The complete drawer will come out of the unit.
5. Clean inside and outside of drawer thoroughly using mild soap and water. Check that drawer slides are clear and clean of any debris.
6. Ensure the drawer roller bearing spins freely. (Clean thoroughly if not spinning freely)
7. Wipe down drawer with a clean, dry rag.
8. When re-inserting the drawer into the unit, hold drawer at 45° angle, lining up drawer slides with guide rails inside of the unit.
9. Insert drawer into guide rails and slowly rotate to level, sliding drawer into the unit.
10. Slide drawer back and forth 1-2 times to ensure correct installation.
11. Reconnect the unit to the power source and return unit to normal operation.



SERVICE INFORMATION

FWE Customer Service: 1-800-222-4393

Email: service@fweco.net

Spare Parts:

Spare or replacement parts may be obtained through a parts supplier or an authorized service agent. There is a basic list of parts as well as a QR Code that can be used to get to the parts website (www.fweparts.com) on a sticker located near the serial tag.





FWE Parts Department
www.FWEparts.com
1-800-222-4393



A HATCO[®] COMPANY

FOOD WARMING EQUIPMENT COMPANY, INC.
COOK | HOLD | TRANSPORT | SERVE | REFRIGERATION | BARS
5599 Highway 31 W, Portland, Tennessee 37148



800-222-4393
WWW.FWE.COM
SALES@FWE.COM

FWE products may be covered under one or more of the following U.S. patents: 288,299; 238,300; 3,952,609; 4,192,991. All specifications subject to change without notice. Errors subject to correction. All rights reserved.
© 25 Food Warming Equipment Company, Inc. | R.25.02