

ECONOMY MOBILE HAND SINK

Self Contained Portable Hand Sink without Water Heater

ECONOMY "HS-E" SERIES

Economy portable hand sink is self-contained to allow safe hand washing and sanitizing in remote locations

- 1** FWE's hands-free portable hand sinks are perfect for any location, making it possible to offer practical hand washing when it is needed to meet safety standards
- 2** Faucet is hands free and engaged by an easy-to-use knee-height push button. Duration of water flow is controlled by a timer factory preset for 5 seconds and is field adjustable
- 3** Made for transport applications - FWE hand sinks are fully constructed of stainless steel and equipped with heavy-duty maintenance-free casters
- 4** Provided with 5 gallon fresh water tank for consistent draw and a 7 gallon waste water tank to hold drainage
- 5** Lockable door prevents unauthorized access for safety and security
- 6** Cord exit can be easily moved to either side, providing flexibility in field placement

***Two year limited warranty**

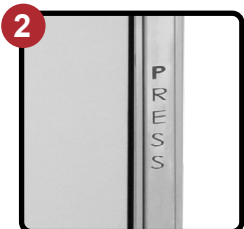

Knee Activated Faucet



Built for Transport



Water Tanks



Lockable Door

SPECIFICATIONS

ECONOMY MOBILE HAND SINK

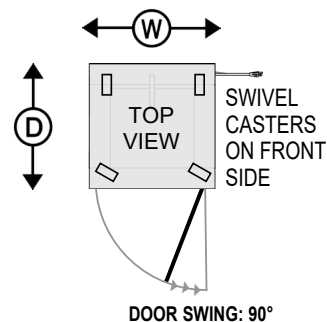
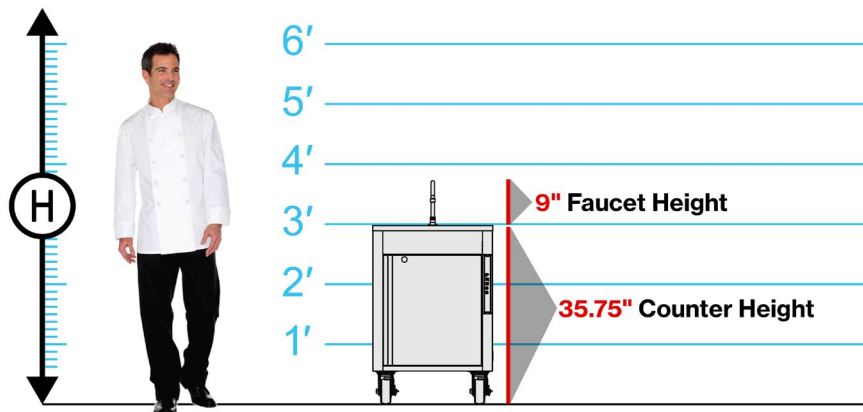

OVERALL EXTERIOR DIMENSIONS IN. (mm) (Height Includes Casters)				CLASS 175		
MODEL NUMBER	HIGH "H"	DEEP "D"	WIDE "W"	NO. OF DOORS	CASTER SIZE	SHIP WT. LBS. (KG)
	44.75" (1137)	24.25" (616)	24.25" (616)	1	5"	190 (87)

ELECTRICAL DATA		
VOLTS	120	220-240
WATTS	240	226
AMPS	2	0.9
HERTZ	60	60
PHASE	Single	Single
PLUG USA	5-15P	6-15P
PLUG CANADA	5-15P	6-15P



Knee Activated Faucet



5 Gallon Fresh Water Tank



7 Gallon Waste Water Tank

Looking for Hand Sinks with a Water Heater?
Scan QR Code to Access the HS Spec Sheet

CONSTRUCTION. Heliarc welded, single unit construction of 20 gauge stainless steel with easy-to-clean coved corners.

DOORS AND LATCHES. Flush mounted, stainless steel door. Full length magnetic recessed workflow handle with locking cam latch. Heavy duty pin style hinges.

CASTERS. Maintenance-free polyurethane tire casters in a configuration of two (2) rigid and two (2) swivel with brake.

WATER CAPACITY. The unit shall include one (1) five gallon fresh water tank and one (1) seven gallon waste water tank.

FAUCET CHARACTERISTICS. Faucet shall be activated by ergonomic, knee-height, push button control. Faucet water pressure shall be two (2) gallons per minute.

ELECTRICAL CHARACTERISTICS. 3 wire grounded 10 foot extension power cord and plug are fed through right side cord exit. Alternative left side cord exit provided. See electrical data chart above for amperage and receptacle configuration.

INSTALLATION. Unit should not be installed in an area where adverse environmental conditions are present.

DOORS
Left hand door hinging
CASTERS
All swivel or larger casters
EXTRAS
Corner bumpers
Extra fresh water tank
Extra waste water tank
Graphic wrap