

# SLANTED HEATED HOLDING SHELVES

NEW MODEL: **HHS-37-3621-ST**

## PERFORMANCE FEATURE SHEET

**Slanted shelves** assist with first in, first out operation, helping to move products forward

**Fast heat up & recover times**  
Reaches 170°F (79.5°C) in less than 15 minutes

**Additional sizing available**  
We can customize the HHS-ST to fit your specific needs and packaging

**All stainless construction**  
for durability and easy cleaning



**Adjustable thermostat controller** is rear-facing on operator side. Includes manager lock-out capability to prevent staff intervention

**Blanket elements** deliver precise and consistent radiant heat, eliminating hot and cold spots



**Dividers** are adjustable at 1" increments and removable to fit various product sizes and a changing menu

**2.5" Adjustable legs** for proper placement on uneven surfaces

**MODEL: HHS-37-3621-ST**



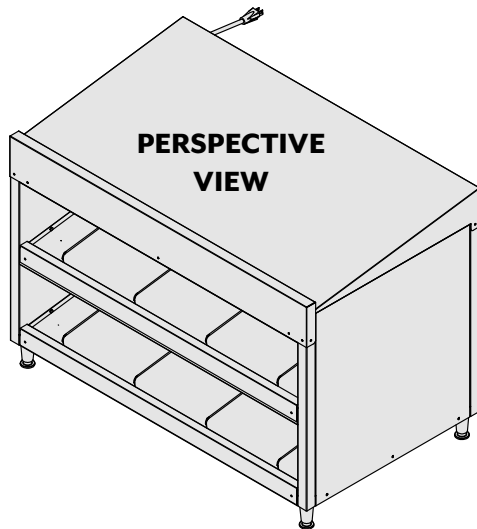
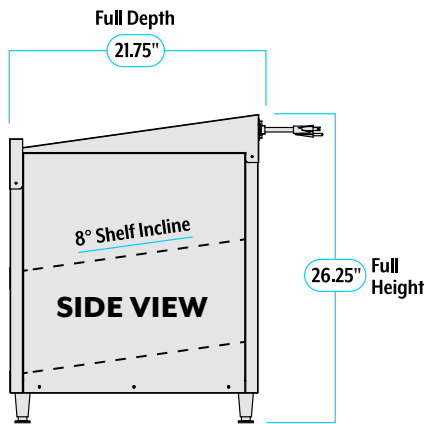
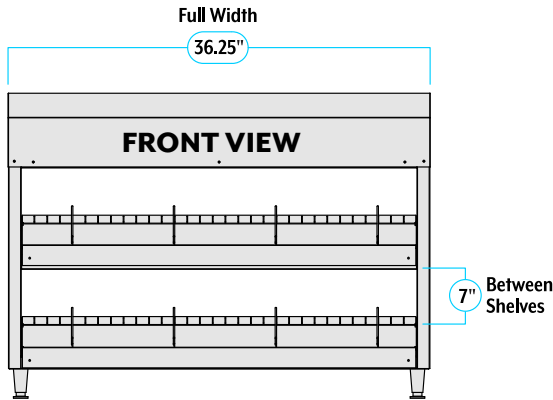

**MODEL NOMENCLATURE**

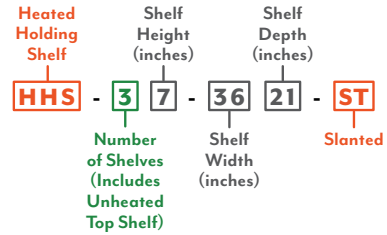

**ELECTRICAL DATA:**

Volts: 120  
 Watts: 694  
 Amps: 5.8  
 Hertz: 50/60  
 Phase: Single



US: 5-15P



CAN: 5-15P

**DIMENSIONS:**

Height: 26.25" (674mm)  
 Depth: 21.75" (553mm)  
 Width: 36.25" (921mm)

**CRATED WEIGHT:**

215lbs (98kg)

**OPTIONAL ACCESSORIES:**

- Individual Power Switches Per Shelf (Add IS)
- Custom Sizing (Consult Factory)
- Powder Coating
- Graphic Wrap (Sides and Header)
- Additional Divider Bars
- Optional Heated Top

